

Alcatel-Lucent OAW-AP120 Series Indoor Access Point Installation Guide

About the Alcatel-Lucent OAW-AP120 Series Access Points

The Alcatel-Lucent OAW-AP120 series of wireless access points support the imminent IEEE 802.11n (currently draft 2.0) standard for high-performance WLAN. These access points use MIMO (Multiple-in, Multiple-out) technology and other high-throughput mode techniques to deliver high-performance, pre-802.11n 2.4GHz and 5GHz functionality while simultaneously supporting existing 802.11a/b/g wireless services. The OAW-AP120 series access points are available in versions with single or dual radios and with integrated antennas or RP-SMA interfaces that support detachable antennas. The OAW-AP120 series access points work only in conjunction with an Alcatel-Lucent WLAN Switch.

The Alcatel-Lucent OAW-AP120 series access points provide the following capabilities:

- Wireless transceiver
- Protocol-independent networking functionality
- IEEE 802.11a/b/g or 802.11n operation as a wireless access point
- IEEE 802.11a/b/g or 802.11n operation as a wireless air monitor
- Compatibility with IEEE 802.3af PoE as well as high power over Ethernet pre-standards (PoE + / 802.3at)
- Central management configuration and upgrades through an Alcatel-Lucent WLAN Switch

Figure 1 OAW-AP120 Series Access Points

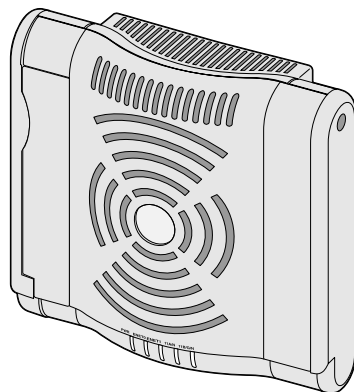

OAW-AP120/124

(3 x RP-SMA interfaces for detachable antennas)

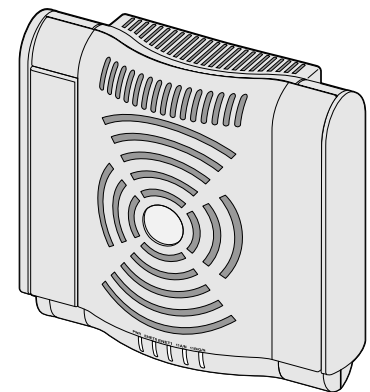

OAW-AP121/125

(3 x integrated dual-band antennas)

Package Contents

- OAW-AP120 series access point
- Installation guide (this document)



Inform your supplier if there are any incorrect, missing, or damaged parts. If possible, retain the carton, including the original packing materials. Use these materials to repack and return the unit to the supplier if needed.



Additional mounting kits for use with the OAW-AP120 series access points are sold separately. Contact your Alcatel-Lucent sales representative for details.

Before You Begin

WLAN Planning

Determine how many Alcatel-Lucent APs are needed for your wireless network deployment and where they will be installed. You can easily accomplish this planning using Alcatel's automated RF Plan site-survey software (available separately). This process is considered WLAN or RF planning and should have been completed during the master Alcatel-Lucent WLAN Switch installation and configuration. In typical Alcatel-Lucent installations, the WLAN switches are configured and installed before the APs.

For WLAN planning assistance, refer to the *RF Plan Installation and User Guide*.

Pre-Installation Network Requirements

After WLAN planning is complete and the appropriate products and their placement have been determined, the Alcatel-Lucent WLAN Switch(es) must be installed and initial setup performed before the Alcatel-Lucent Access Points are deployed.

For initial setup of the WLAN Switch, refer to the *Alcatel-Lucent AOS-W Quick Start Guide* for the software version installed on your controller.

Pre-Installation Checklist

Before installing your OAW-AP120 series access point, be sure that you have the following:

- For the OAW-AP120/OAW-AP124: External antennas as specified in the network deployment plan
- CAT5 UTP cable of required length
- One of the following power sources:
 - IEEE 802.3af-compliant Power over Ethernet (PoE) source
 - Supports full functionality for OAW-AP120/OAW-AP121; supports reduced functionality for OAW-AP124/OAW-AP125
 - IEEE Power Over Ethernet + (PoE+) source output at 56Volts @ 350mA
 - The POE source can be any power source equipment (PSE) controller or midspan PSE device
 - Alcatel-Lucent AP AC-DC adapter kit (sold separately)
- Alcatel-Lucent WLAN Switch provisioned on the network:
 - Layer 2/3 network connectivity to your access point
 - One of the following network services:
 - Alcatel-Lucent Discovery Protocol (ADP)
 - DNS server with an "A" record
 - DHCP Server with vendor-specific options

Summary of the Setup Process



It is important that you verify the items listed under [Pre-Installation Checklist](#) before you attempt to set up and install an OAW-AP120 series AP.

Successful setup of an OAW-AP120 series access point consists of five tasks, which must be performed in this order:

1. Verify pre-installation connectivity.
2. Identify the specific installation location for each AP.
3. Install each AP.
4. Verify post-installation connectivity.
5. Configure each AP.



Alcatel, in compliance with governmental requirements, has designed the OAW-AP120 series access points so that only authorized network administrators can change the settings. For more information about AP configuration, refer to the *Alcatel-Lucent AOS-W Quick Start Guide* and *Alcatel-Lucent OS User Guide*.



Access points are radio transmission devices and as such are subject to governmental regulation. Network administrators responsible for the configuration and operation of access points must comply with local broadcast regulations. Specifically, access points must use channel assignments appropriate to the location in which the access point will be used.

Verifying Pre-Installation Connectivity

Before you install APs in a network environment, make sure that the APs will be able to locate and connect to the WLAN Switch when powered on.

Specifically, you must verify the following conditions:

- When connected to the network, each AP is assigned a valid IP address
- APs are able to locate the WLAN Switch (WLAN Switch Discovery)

Refer to the *Alcatel-Lucent AOS-W Quick Start Guide* for instructions on locating and connecting to the WLAN Switch.

Identifying Specific Installation Locations



RF Radiation Exposure Statement: This equipment complies with FCC RF radiation exposure limits. This equipment should be installed and operated with a minimum distance of 13.78 inches (35 cm) between the radiator and your body for 2.4 GHz and 5 GHz operations. This transmitter must not be co-located or operating in conjunction with any other antenna or transmitter. When operated in the 5.15 to 5.25 GHz frequency range, this device is restricted to indoor use to reduce the potential for harmful interference with co-channel Mobile Satellite Systems.

You can mount the OAW-AP120 series access point on a wall or on the ceiling. Use the AP placement map generated by Alcatel's RF Plan software application to determine the proper installation location(s). Each location should be as close as possible to the center of the intended coverage area and should be free from obstructions or obvious sources of interference. These RF absorbers/reflectors/interference sources will impact RF propagation and should have been accounted for during the planning phase and adjusted for in RF plan.

Unidentified Known RF Absorbers/Reflectors/Interference Sources

Identifying known RF absorbers, reflectors, and interference sources while in the field during the installation phase is critical. Make sure that these sources are taken into consideration when you attach an AP to its fixed location.

RF absorbers include:

- Cement/concrete: Old concrete has high levels of water dissipation, which dries out the concrete, allowing for potential RF propagation. New concrete has high levels of water concentration within the concrete, blocking RF signals.
- Natural Items: Fish tanks, water fountains, ponds, and trees
- Brick

RF reflectors include:

- Metal Objects: Metal pans between floors, rebar, fire doors, air conditioning/heating ducts, mesh windows, blinds, chain link fences (depending on aperture size), refrigerators, racks, shelves, and filing cabinets
- Do not place an AP between two air conditioning/heating ducts. Make sure that APs are placed below ducts to avoid RF disturbances.

RF interference sources include:

- Microwave ovens and other 2.4 or 5 GHz objects (such as cordless phones)
- Lunch rooms and call centers with cordless headsets

Installing the AP



Service to all Alcatel-Lucent products should be performed by trained service personnel only.

Using the Integrated Wall-Mounting Slots

The keyhole-shaped slots on the back of the AP can be used to attach the device upright to an indoor wall or shelf. When you choose the mounting location, allow additional space at the right of the unit for cables.



For product dimensions, see [Product Specifications](#) in this guide. Allow 2 inches (5 cm) of additional space at the right side of the installed unit for cables, and make sure enough space is available for antenna articulation.

1. At the mounting location, install two screw on the wall or shelf, 1 7/8 inches (4.7 cm) apart. If you are attaching the device to drywall, Alcatel-Lucent recommends using appropriate wall anchors (not included).
2. Align the mounting slots on the rear of the AP over the screws and slide the unit into place (see [Figure 2](#)).

Figure 2 *Installing the OAW-AP120 series Access Point on a Wall*

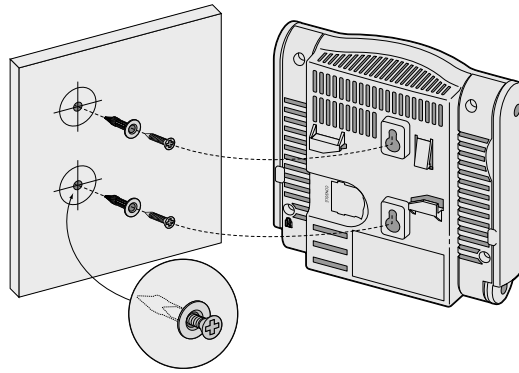

3. On the OAW-AP121 or OAW-AP125, orient the antennas. For best performance, swivel the antennas so that they are oriented vertically, preferably in the same plane, parallel to the wall (see [Figure 3](#)).

Figure 3 *Antenna Orientation on a Wall-Mounted OAW-AP121/OAW-AP125*

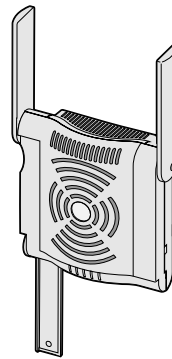

On the OAW-AP120 or OAW-AP124, install the external antennas according to the manufacturer's instructions, and connect the antennas to the antenna interfaces on the AP (see [Figure 4](#)).

Figure 4 *Antenna Interfaces on the OAW-AP120/OAW-AP124*

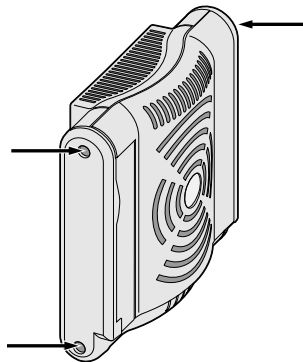

Using the Integrated Ceiling Tile Rail Slots

The snap-in tile rail slots on the rear of the AP can be used to securely attach the device directly to a 15/16" wide, standard ceiling tile rail.



Make sure the AP fits securely on the ceiling tile rail when hanging the device from the ceiling, because poor installation could cause it to fall onto people or equipment.

1. Pull the necessary cables through a prepared hole in the ceiling tile near where the AP will be placed.
2. If necessary, connect the console cable to the console port on the back of the AP.
3. Hold the AP next to the ceiling tile rail with the ceiling tile rail mounting slots at approximately a 30-degree angle to the ceiling tile rail (see [Figure 5](#)). Make sure that any cable slack is above the ceiling tile.

Figure 5 *Orienting the Ceiling Tile Rail Mounting Slots*

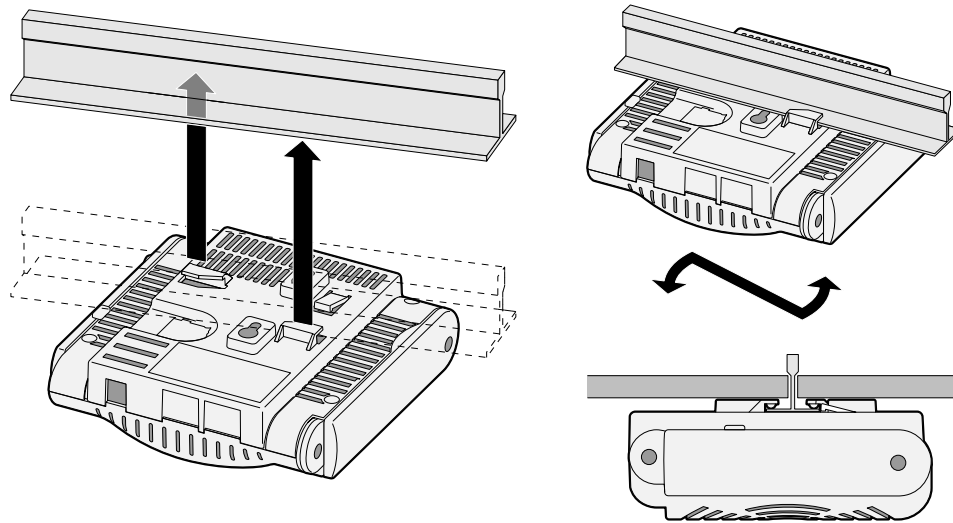

4. Pushing toward the ceiling tile, rotate the AP clockwise until the device clicks into place on the ceiling tile rail.
5. On the OAW-AP121 or OAW-AP125, orient the antennas. For best results, rotate the antennas so that they are vertical (perpendicular to the body of the AP) (see [Figure 6](#)).

Figure 6 *Antenna Orientation on a Ceiling-Mounted OAW-AP121/OAW-AP125*

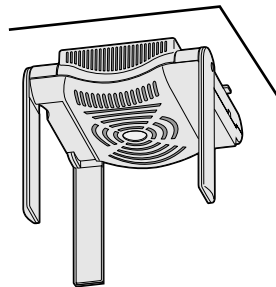

On the OAW-AP120 or OAW-AP124, install the external antennas according to the manufacturer's instructions, and connect the antennas to the antenna interfaces on the AP (see [Figure 4](#)).

Connecting Required Cables

Install cables in accordance with all applicable local and national regulations and practices.

Ethernet Ports

The RJ45 Ethernet ports (ENET0 and ENET1) support 100/1000Base-T auto-sensing MDI/MDX connections. Use these ports to connect the AP to a twisted pair Ethernet LAN segment or directly to an

Alcatel-Lucent WLAN Switch. Use a 4- or 8-conductor, Category 5 UTP cable up to 100 m (325 feet) long.



Alcatel-Lucent OAW-AP12x APs are intended only for installation in Environment A as defined in IEEE 802.3.af, Power over Ethernet. All interconnected equipment must be contained within the same building, including the interconnected equipment's associated LAN connections.

The 100/1000 Mbps Ethernet ports are on the bottom of the AP. These ports have RJ-45 female connectors with the pin-outs shown in [Table 1](#).

Table 1 Connector for Ethernet Ports ENET0 and ENET1

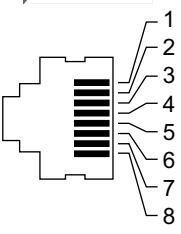
Connector	Pin	Signal Name	GE Connection	FE Connection	PoE
	1	BI_DA+	Bi-directional pair A+	RX+	POE negative
	2	BI_DA-	Bi-directional pair A-	RX-	POE negative
	3	BI_DB+	Bi-directional pair B+	TX+	POE positive
	4	BI_DC+	Bi-directional pair C+	Spare pair	POE positive
	5	BI_DC-	Bi-directional pair C-	Spare pair	POE positive
	6	BI_DB-	Bi-directional pair B-	TX-	POE positive
	7	BI_DD+	Bi-directional pair D+	Spare pair	POE negative
	8	BI_DB-	Bi-directional pair D-	Spare pair	POE negative

Serial Console Port

The serial console port allows you to connect the AP to a serial terminal or a laptop for direct local management. This port is an RJ-45 female connector with the pinouts described in [Table 2](#). Connect this port in one of the following ways:

- Connect it directly to a terminal or terminal server using an Ethernet cable.
- Use a modular adapter to convert the RJ-45 (female) connector on the AP to a DB-9 (male) connector, and connect the adapter to a laptop using an RS-232 cable. See [Figure 7](#) for connector details of the adapter.

Table 2 Connector for Serial Console Port

Connector	Pin	Signal Name	Function	
	3	TXD	Transmit	
	4	GND	Ground	
	5	GND	Ground	
	6	RXD	Receive	
	Pins not listed are not connected.			

Figure 7 RJ-45 (Female) to DB-9 (Male) Modular Adapter Conversion



Power Connection

The OAW-AP120 series AP has a single 5V DC power jack socket to support powering through an AC-to-DC mains electric power adapter.

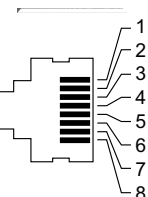
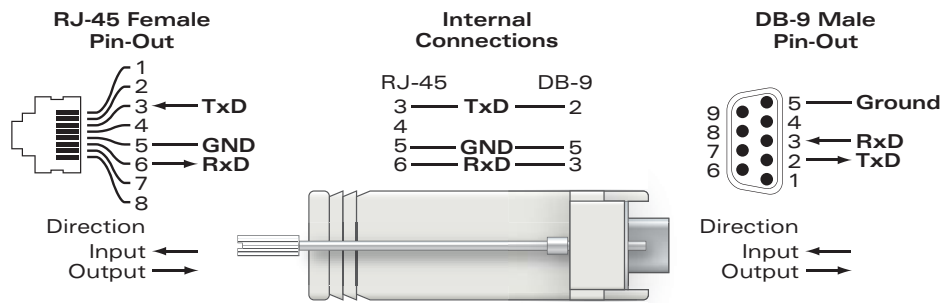
Connecting a Security Cable

To provide added security for the AP, you can attach a security cable to the back of the unit (see [Figure 8](#)).

Figure 8 Security Lock Connection

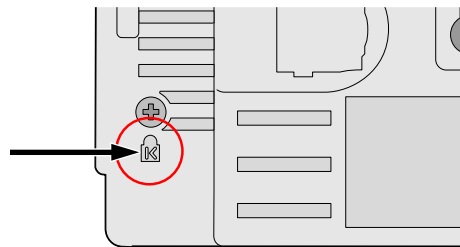

Verifying Post-Installation Connectivity

The integrated LEDs on the AP can be used at this point to verify that the AP is receiving power and initializing successfully (see [Table 3](#)). Refer to the *Alcatel-Lucent AOS-W Quick Start Guide* for further details on verifying post-installation network connectivity.

Table 3 OAW-AP120 Series LED Meanings

LED	Color/State	Meaning
PWR	Green Steady	Power on, device ready
	Green flashing	System initializing
ENET 0 (100/1000 Mbps)	Green/Amber off	No link
	Green on	1000 Mbps link
	Amber on	10/100 Mbps link
	Green/amber blinking	Data activity
ENET 1 (100/1000 Mbps)	Green/Amber off	No Link
	Green on	1000 Mbps link
	Amber on	10/100 Mbps link
	Green/amber blinking	Data activity
11A/N	Amber on	Wireless link is legacy 11a.
	Green on	Wireless link is 11n 5Ghz band.

Table 3 OAW-AP120 Series LED Meanings

LED	Color/State	Meaning
11B/G/N	Amber	Wireless link is legacy 11b or 11g.
	Green	Wireless link is 11n 2.4Ghz band.

Configuring the OAW-AP12x

AP Provisioning/Reprovisioning

Provisioning parameters are unique to each AP. These local AP parameters are initially configured on the WLAN Switch which are then pushed out to the AP and stored on the AP itself. Alcatel-Lucent recommends that provisioning settings be configured via the Alcatel-Lucent AOS-W Web UI only. Refer to the *Alcatel-Lucent AOS-W User Guide* for complete details.

AP Configuration

Configuration parameters are network or controller specific and are configured and stored on the WLAN Switch. Network configuration settings are pushed out to the AP(s) but remain stored on the WLAN Switch.

Configuration settings can be configured via the Alcatel-Lucent AOS-W Web UI, Alcatel-Lucent AOS-W CLI, or Alcatel-Lucent OmniVista Mobility Manager Software. Refer to their respective guides for further details: the *Alcatel-Lucent AOS-W User Guide* or *Alcatel-Lucent OmniVista Mobility Manager Software User Guide*.

Product Specifications

Mechanical

- Dimensions (antenna stowed) (HxWxD):
 - 4.9 inches x 5.13 inches x 2 inches
 - 12.4 cm x 13 cm x 5.1 cm
- Weight: 15 oz/0.42 kg
- Shipping Dimensions:
 - 9.5 inches x 7.25 inches x 4.5 inches
 - 24.1 cm x 18.4 cm x 11.4 cm
- Temperature:
 - Operating: 0°C to 50°C (32°F to 122°F)
 - Storage: -10°C to 70°C (14°F to 158°F)
- Relative Humidity: 5% to 95% non-condensing
- Altitude: 8,000 ft @ 28°C (82.4°F)
- Mounting: Wall, ceiling, or desktop mountable
- Antennas:
 - 3 integrated articulating dual-band antenna elements (OAW-AP121, OAW-AP125)
 - 3 RP-SMA interfaces for external antennas (OAW-AP120, OAW-AP124)
- Visual Status Indicators (LEDs): See [Table 3](#)

Electrical

- Ethernet:
 - 2 x 100/1000 Base-T auto-sensing Ethernet RJ-45 Interfaces
 - MDI/MDX
 - IEEE 802.3 (10Base-T), IEEE 802.3u (100Base-T), IEEE 802.3ab (1000Base-T)
 - Power over Ethernet (IEEE 802.3af compliant), 48V DC/200mA (see [Table 1](#) for pin configuration)
- Power:
 - 5 VDC power interface, supports powering through an AC-to-DC mains electric power adapter



If a power adapter other than the one provided by Alcatel-Lucent is used in the US or Canada, it should be cULus (NRTL) Listed, with an output rated 5 VDC, minimum 4A, marked “LPS” or “Class 2,” and suitable for plugging into a standard power receptacle in the US and Canada.

- POE support on Ethernet ports:
 - 802.3af-compliant POE sourcing devices
 - POE+ (56 V @ 350 mA)

Wireless LAN

- Network Standards: IEEE 802.11b, IEEE 802.11g, IEEE 802.11a, and IEEE 802.11n
- Antenna Type:
 - Integrated 802.11a/b/g/n omni-directional high-gain antenna
 - Detachable 802.11a/b/g/n omni-directional high-gain antenna
- Antenna Gain (Integrated Antennas):
 - 2.4 – 2.5 GHz/3.2 dBi (max)
 - 5.180 – 5.825 GHz/5.2 dBi (max)
- Radio Technology:
 - Orthogonal Frequency Division Multiplexing (OFDM)
 - Direct Sequence Spread Spectrum (DSSS)
- Radio Modulation Type:
 - 802.11b - CCK, BPSK, QPSK
 - 802.11g - CCK, BPSK, QPSK, 16-QAM, 64-QAM
 - 802.11a - BPSK, QPSK, 16-QAM, 64-QAM
 - 802.11n draft 2.0
- Media Access Control: CSMA/CA with ACK
- Supported Frequency Bands 2.4GHz:
 - 2.400 ~ 2.4835GHz (Global), channels country specific
- Supported Frequency Bands 5GHz:
 - 5.150 ~ 5.250GHz (low band), country-specific
 - 5.250 ~ 5.350GHz (mid band), country-specific
 - 5.470 ~ 5.725GHz (Europe), country-specific
 - 5.725 ~ 5.825GHz (high band), country-specific

- Data Rates:
 - 802.11b - 1, 2, 5.5, 11 Mbps per channel
 - 802.11g - 6, 9, 12, 18, 24, 36, 48 and 54 Mbps per channel
 - 802.11a - 6, 9, 12, 18, 24, 36, 48 and 54 Mbps per channel
 - 802.11n - Data rate MCS0 – MCS15 (from 6.5 Mbps to 300 Mbps)

Safety and Regulatory Compliance

Alcatel-Lucent provides a multi-language document that contains country-specific restrictions and additional safety and regulatory information for all Alcatel-Lucent access points. This document can be viewed or downloaded from the following location:

<https://service.esd.alcatel-lucent.com>



RF Radiation Exposure Statement: This equipment complies with FCC RF radiation exposure limits. This equipment should be installed and operated with a minimum distance of 13.78 inches (35 cm) between the radiator and your body for 2.4 GHz and 5 GHz operations. This transmitter must not be co-located or operating in conjunction with any other antenna or transmitter. When operated in the 5.15 to 5.25 GHz frequency range, this device is restricted to indoor use to reduce the potential for harmful interference with co-channel Mobile Satellite Systems.

Proper Disposal of Alcatel-Lucent Equipment

For the most current information about Global Environmental Compliance and Alcatel-Lucent products, see our website at <http://www.alcatel-lucent.com/enterprise>.

Waste of Electrical and Electronic Equipment

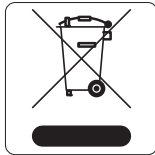

Alcatel-Lucent products at end of life are subject to separate collection and treatment in the EU Member States, Norway, and Switzerland and therefore are marked with the symbol shown at the left (crossed-out wheelie bin). The treatment applied at end of life of these products in these countries shall comply with the applicable national laws of countries implementing Directive 2002/96EC on Waste of Electrical and Electronic Equipment (WEEE).

European Union RoHS



Alcatel-Lucent products also comply with the EU Restriction of Hazardous Substances Directive 2002/95/EC (RoHS). EU RoHS restricts the use of specific hazardous materials in the manufacture of electrical and electronic equipment.

Specifically, restricted materials under the RoHS Directive are Lead (including Solder used in printed circuit assemblies), Cadmium, Mercury, Hexavalent Chromium, and Bromine. Some Alcatel-Lucent products are subject to the exemptions listed in RoHS Directive Annex 7 (Lead in solder used in printed circuit assemblies). Products and packaging will be marked with the “RoHS” label shown at the left indicating conformance to this Directive.

China RoHS



Alcatel-Lucent products also comply with China environmental declaration requirements and are labeled with the “EFUP 50” label shown at the left.

有毒有害物质声明

Hazardous Materials Declaration

部件名称 (Parts)	有毒有害物质或元素 (Hazardous Substances)					
	铅 Lead (Pb)	汞 Mercury (Hg)	镉 Cadmium (Cd)	六价铬 Chromium VI Compounds (Cr ⁶⁺)	多溴联苯 Polybrominated Biphenyls (PBB)	多溴二苯醚 Polybrominated Diphenyl Ether (PBDE)
电路板 PCA Board	X	O	O	O	O	O
机械组件 Mechanical Subassembly	X	O	O	O	O	O
O: 表示该有毒有害物质在该部件所有均质材料中的含量均在SJ/T11363-2006标准规定的限量要求以下。 This component does not contain this hazardous substance above the maximum concentration values in homogeneous materials specified in the SJ/T11363-2006 Industry Standard.						
X: 表示该有毒有害物质至少在该部件的某一均质材料中的含量超出SJ/T11363-2006标准规定的限量要求。 This component does contain this hazardous substance above the maximum concentration values in homogeneous materials specified in the SJ/T11363-2006 Industry Standard.						
对销售之日的所售产品, 本表显示, 供应链的电子信息产品可能包含这些物质。 This table shows where these substances may be found in the supply chain of electronic information products, as of the date of sale of the enclosed product.						
此标志为针对所涉及产品的环保使用期标志。 某些零部件会有一个不同的环保使用期(例如, 电池单元模块)贴在其产品上。 此环保使用期限只适用于产品是在产品手册中所规定的条件下工作。 The Environment- Friendly Use Period (EFUP) for all enclosed products and their parts are per the symbol shown here. The Environment- Friendly Use Period is valid only when the product is operated under the conditions defined in the product manual.						

Battery Replacement

Batteries included with Alcatel-Lucent products must be replaced by qualified Alcatel-Lucent service personnel only. Contact Alcatel-Lucent for battery replacement. Do not attempt to replace the battery. There is a risk of explosion if you install the wrong type of battery.